

## Common SDL1X/X-E performance (not in the data sheet)

June 07, 2019

As with many instruments, there are often details of operation that may not be contained in the manuals or data sheets. To help clarify operations and functions, we created this list to help provide answers to common questions about the SIGLENT SDL1X/X-E models of electronic DC loads:

1. Are the **Voltage Sensing** inputs (rear panel connector, **Sense +**, and **Sense -**) made up as true differential input?

Yes, the Voltage Sense inputs are true different inputs.

2. What is the input resistance (impedance) for each of the "+" and "-" sense inputs?

200 kΩ.

3. Would there be any significant leakage current into the **Voltage Sensing** inputs when the output is programmed to NOT sink any current (current = zero), while the voltage is not zero?

Yes, there is some leakage current. Because the sense channel has a resistance. For example, if the maximum input voltage is 150 V, the current =  $150 \text{ V} / (200 \text{ k}\Omega * 2) = 0.375 \text{ mA}$ .

4. What is the permitted voltage range for each of the "+" and "-" inputs? (For Sense + it must be at least +150 V, the capability of the instrument?)

150V; The Sense '+' and '-' do not support reverse connections and it also does not have the reverse warning message.

5. What is the maximum NEGATIVE voltage that can be safely tolerated on the Sense "+" and Sense "-" without burning the unit?

< 15V.

6. Are the **External Programming** inputs (rear panel connector, **EXT PRG +**, and **EXT PRG -**) made up as true differential input?

No, it is not a differential input. Below is the circuit diagram:

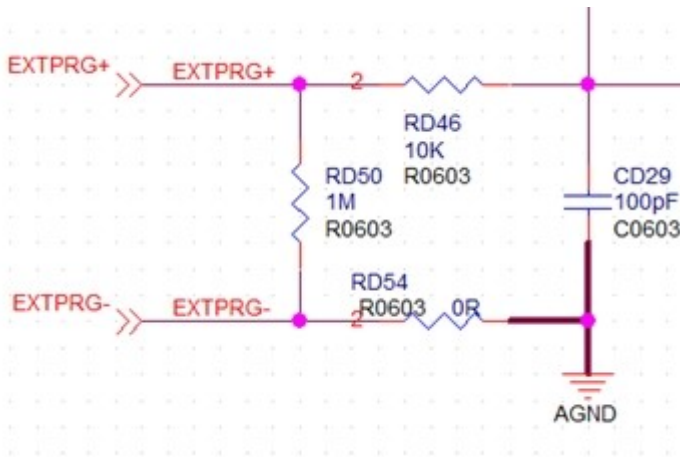

7. What is the input resistance (impedance) for each of the “+” and “-” inputs?

The ext prg ‘+’ is 1M ohm and ‘-’ is 0 ohms (GND).

8. What is the permitted voltage range for each of the “+” and “-” inputs? (It is understood that the maximum differential Programming Input voltage is 10 V)

The maximum Ext prg ‘+’ voltage is 15 V. Ext prg ‘-’ is GND. Reverse polarity connections will damage the circuit.

9. What is the maximum NEGATIVE voltage that can be tolerated on the EXT PRG “+” and EXT PRG “-” without burning the unit?

The maximum Ext prg ‘+’ voltage is 15 V. Ext prg ‘-’ is GND. so it can not reverse connection otherwise damage the circuit.

10. Is the continuity to the unit’s GND required for these inputs (for passage of the leakage current from EXT PRG “+” and EXT PRG “-”, for example), or the programming voltage source should be completely floating with respect to the unit’s GND?

The GND of the programming voltage source must be shared with the input device, same as input -.

11. Can the negative EXT PRG “-” input and Return for the programming voltage source be simply connected to the unit’s GND (rear panel, GND connection right next to the EXT PRG “-” ?

Yes, EXT PRG ‘-’ = GND

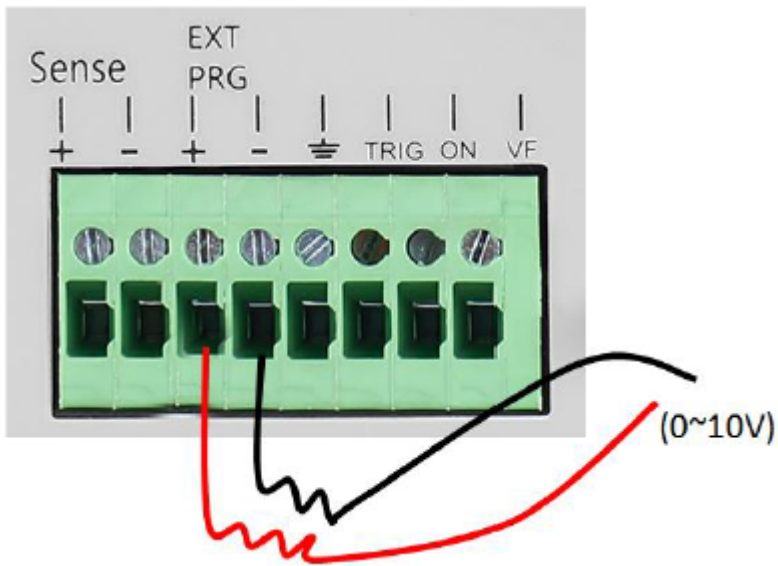

12. What is the output impedance of the monitoring outputs (rear panel, **I Monitor** and **V Monitor**, BNC connectors)?

5 k $\Omega$ .



### **North American Headquarters**

SIGLENT Technologies NA  
6557 Cochran Rd Solon, Ohio 44139  
Tel: 440-398-5800  
Toll Free: 877-515-5551  
Fax: 440-399-1211  
[info@siglent.com](mailto:info@siglent.com)  
[www.siglentamerica.com/](http://www.siglentamerica.com/)

### **European Sales Offices**

SIGLENT TECHNOLOGIES GERMANY GmbH  
Staetzlinger Str. 70  
86165 Augsburg, Germany  
Tel: +49(0)-821-666 0 111 0  
Fax: +49(0)-821-666 0 111 22  
[info-eu@siglent.com](mailto:info-eu@siglent.com)  
[www.siglenteu.com](http://www.siglenteu.com)

### **Asian Headquarters**

SIGLENT TECHNOLOGIES CO., LTD.  
Blog No.4 & No.5, Antongda Industrial Zone,  
3rd Liuxian Road, Bao'an District,  
Shenzhen, 518101, China.  
Tel: + 86 755 3661 5186  
Fax: + 86 755 3359 1582  
[sales@siglent.com](mailto:sales@siglent.com)  
[www.siglent.com/ens](http://www.siglent.com/ens)